

USER'S MANUAL URBAN COMBI



Edition: 01
Date: Tuesday 15 November 2016

RIONED
P.O. Box 5070
5004 EB Tilburg
The Netherlands
Telephone: +31 13 5479100
E-mail: info@rioned.com
Internet: www.rioned.com

Rioned

© Copyright 11/16 Rioned/RIOR B.V.Tilburg - The Netherlands

All rights reserved. No part of this publication may be copied or published by means of printing, photocopying, microfilm or otherwise without the prior written consent of **RIONED**. This restriction also holds for the corresponding drawings and diagrams.

RIONED has the right to change parts at any time without any prior or direct warning to the client. Also, the contents of this manual can be changed without any prior warning.

This manual is to be used only for this machine.

For extra information on adjustments, maintenance and repair, please contact the technical department of your dealer.

Foreword.

This user's manual is a manual for the professional user.
This user's manual has the purpose to control the machine in a safe manner and must be saved with the machine.
The photos and drawings help you understand the text.
First the user's manual gives you an overview of the most important safety aspects.
Then we explain how the machine is built up and the general working of the machine.
Chapter "Technical specifications" gives you information about the working characteristics, performance under normal use and construction specifications.
"Control" is the next chapter. This chapter explains how to use the machine systematically.
With chapter "Maintenance", the user can do small maintenance on the machine.
Chapter "Trouble shooting" has the purpose to solve simple defects.
Finally gives the chapter "Appendix" information about electrical and/or hydraulic connections.

Table of contents

1	Introduction	7
	1.1 Use.....	7
2	Security	9
	2.1 Instruction indications in this manual.....	9
	2.2 Description security measures.....	9
	2.3 Personnel protection outfit.....	9
	2.4 Warnings.....	10
	2.5 Personnel qualification and education.....	10
	2.6 Danger that can occur if the security regulations aren't observed	10
	2.7 Working safely.....	11
	2.8 Security regulations for the user and technical service.....	11
	2.9 Security regulations for maintenance, inspection, and mounting ac- tivities.....	11
	2.10 Making changes and fabricate spare parts.....	11
	2.11 Improper use.....	11
3	Technical specifications	13
	3.1 General.....	13
	3.2 Pump.....	13
	3.3 Vacuum pump.....	13
	3.4 Customer service.....	13
4	Construction	15
	4.1 Vehicle.....	15
	4.2 Control box.....	19
	4.3 Corona.....	20
5	Control	21
	5.1 Before starting.....	21
	5.2 Starting the engine in the cabine:.....	22
	5.3 Starting the engine at the back of the unit:.....	22
	5.4 Unclogging a drain.....	25
	5.5 Cleaning a wall, terrace or floor.....	28
	5.6 Stop working.....	28
	5.7 PTO OFF.....	29
	5.8 Using the device during periods of frost (no option antifreeze tank available).....	29
	5.9 Additional preparations when preparing for use:.....	29
6	Using the vacuum device	31
	6.1 Before use:.....	31
	6.2 Fill the dirt water tank:.....	31
	6.3 Empty the dirt water tank:.....	32
7	Symbols	33
	7.1 Pressure gauge.....	33
	7.2 Pressure regulator.....	33

7.3	Valve control.....	33
7.4	Security sticker.....	34
8	Options.....	35
8.1	ECO mode OFF	35
8.2	ECO versions.....	37
8.3	Riomote Control.....	38
8.4	Management	41
8.5	Hydraulic reel control	42
8.6	Run dry protection	42
8.7	Flashing orange light	42
8.8	Hose guide.....	43
9	Maintenance.....	45
9.1	Daily maintenance	45
9.2	Weekly maintenance	45
9.3	Minor servicing	45
9.4	Hydraulic system	46
9.5	Clean the vacuum tank.....	46
9.6	Maintenance vacuum pump.....	46
9.7	Cleaning the suction filter	47
9.8	Cleaning the siphon.....	47
9.9	Extensive periodical maintenance.....	47
9.10	Maintenance scheme	48
10	Troubleshooting	49
11	Exploded views and spare parts lists.....	53
11.1	Pressure regulator (ULH261).....	54
11.2	Siphon	55
12	Appendix	57
12.1	EC declaration Of Conformity For Machinery	57
12.2	Sales Managers	58
12.3	Electric plan	59
12.4	Electric plan	60
12.5	Switch plan	61
12.6	Wiring lights.....	62
12.7	Hydraulic oil.....	63
12.8	Hydraulic scheme.....	64
12.9	Dimensions	65
12.10	Pneumatic circuit	66
13	Index	67

1 INTRODUCTION

RIONED thanks you for your purchase of the RIONED drain and sewer-cleaning machine. We recommend that you read this manual thoroughly and see that the machine is handled and maintained in the proper manner. If your machine should give trouble and needs servicing, when you want to order parts, or if you have any questions, contact your RIONED dealer.

The machine is built by:

RIONED

P.O. Box 5070
5004 EB Tilburg
The Netherlands
Telephone: +31 13 5479100
E-mail: info@rioned.com
Internet: www.rioned.com

The Rioned high-pressure device has been especially designed and manufactured for cleaning drains, walls, floors, and terraces. For cleaning drains, special nozzles are included in the delivery; for all other purposes, the spray gun, which is also included, can be used.

This manual contains all the necessary information concerning control and maintenance. If the device is positioned correctly, properly controlled, and regularly maintained, a warranty will be given according to the general conditions of delivery. However, should it arise that the control and maintenance procedures are not diligently followed, the warranty will become invalid.

Use this machine only for cleaning drains, walls, floors and terraces and to drain liquid with or without pollution like sand, stones etc.

Use this machine only outside. If you want to work inside a building you have to ensure that there is enough ventilation.

During the time that the weather conditions are bad, we recommend that you do not use the machine (lightning)!

Only authorised personnel may use the machine.

The machine can not be used in an explosive environment.

Fill the clean water tank only with water.

It is strongly forbidden to drain flammable materials, chemicals, and elements with special regulations.

In this manual you will find all necessary information concerning operations and maintaining your machine. If handled properly, your machine is guaranteed according the general delivery conditions.

1.1 Use

The integrated engine drives the high-pressure pump, the hydraulic pump, and the vacuum pump via a hydraulic system.

The high-pressure pump receives water from the water tank via the water filter and pressurises it. The pressure can be continuously adjusted. The pressurised water leaves the machine via the high-pressure hose on the reel.

The vacuum pump is connected to the vacuum tank. When this pump creates a vacuum, the tank gets filled.

The hydraulic pump drives via a hydraulic system the hose reel.

2 SECURITY

Be responsible for other people when you are working with this machine.

This manual contains instructions for fundamental conditions that must be followed when using and maintaining this machine.

That is why it is necessary that authorised and qualified personnel must read the user's manual and the user's manual must always be available with the machine. Near the general regulations in this chapter, you must also follow the security regulations in the other chapters.

2.1 Instruction indications in this manual

The in this manual containing security instructions, which are dangerous if they are not obeyed, are marked with general security signs.



Security sign DIN 4844-W9.

2.2 Description security measures

- Emergency stop

The machine is equipped with an emergency stop. By operating this stop, the machine will stop immediately. Do not use the button for normal stopping. Only use it when dangerous situations occur. After use, turn the emergency stop in order to be able to start up again. Make sure the emergency stop can always be reached.

- Over-pressure valve

Protects the pipe system and reservoir.

- Pressure regulator

The pressure regulator looks to it that the working pressure never gets too high. It functions like a safety valve.

- Security covers

This machine is equipped with several safety covers over parts that are rotating. It is forbidden to remove these safety covers during operation of this machine. You can only remove them if there is maintenance on the machine. Stop the machine.

2.3 Personnel protection outfit

- Ear protector
- Protection looking glasses
- Gloves (Recommended)
- Waterproof work clothing (Recommended)

- Spray boots by use of spray gun (Recommended)

2.4 Warnings

It is prohibited to drive with the water tank and vacuum tank full at the same time when the maximum allowed load of the vehicle is overstepped.!

Never block the control levers in any way, otherwise mentioned.

Put the personnel protection outfit on **BEFORE** you start the machine.

Ensure that the spraying nozzle does not leave the drain.

Before using a spray gun, you must always set the pressure below the maximum (\pm the half of the maximum pressure). You must do this before you start the machine.

Never exceed the maximum pressure that is marked on the manometer when using the spray gun.

After use of the high-pressure circuit depressurise it.

Look out for electric connections and other electric components if you are cleaning with a spray gun!

Never let the high-pressure hose spray outside a sewer, drain or pipe.

Do not let the machine operate without supervision.

Never stands between the tank and the tank cover unless there are precautions to prevent closing the tank cover.

Never stand behind the tank cover when it is opened or closed.

2.5 Personnel qualification and education

Personnel that use, maintain, and inspect the machine must have the right qualifications for this job.

Responsibility and authorisation of the personnel and the supervision on the personnel must be embedded. If the knowledge is not present, the user must provide for the necessarily education.

2.6 Danger that can occur if the security regulations aren't observed

If the security regulations are not observed, danger can occur for personnel and for the environment.

No amends are given if the regulations are not observed.

If the regulations are not observed, this can results in:

- Failure of important functions of the machine.
- Failure of prescribes methods for maintenance.
- Exposure of persons to dangers of electrical or mechanical failures

2.7 Working safely

The in this manual named security prescriptions, the national prescriptions to prevent accidents and the internal labour, company and security prescriptions must be followed by the user.

2.8 Security regulations for the user and technical service

- Protections of moving parts (for example couplings) may not be removed if the machine is working.
- Leakage of dangerous mediums must be disposed in a manner that there is no danger for the personnel and environment. Statutory regulations must be followed.
- Danger caused by electricity must be excluded.

2.9 Security regulations for maintenance, inspection, and mounting activities

- The user sees to it that qualified technicians do all maintenance, inspection and mounting activities. They must study the manual thoroughly.
- Maintenance may only be done when the machine is not functioning.
- The in the user's manual mentioned handling to stop the machine must be notified.
- Directly after maintenance of the machine, all the security and protection facilities must be functionally.
- Before starting the machine again, you must follow the instructions correctly.

2.10 Making changes and fabricate spare parts

Changes to the machine are only permitted if Rioned has given written authorisation. The use of original spare parts and accessories is for the safety necessary. Rioned is not responsible for injuries or damages if other spare parts are used.

2.11 Improper use

The security during working with the machine is only guaranteed if the use of the machine is conforming the user's manual. The limits that are written in chapter "Technical Specifications" and "Appendix" may never be overstepped.

If the machine does not work or give troubles, it is forbidden to work further with the machine. Telephone your dealer or the technical department of your dealer.

This manual contains all the necessary information concerning control and maintenance. If the device is positioned correctly, properly controlled, and regularly maintained, a warranty will be given according to the general conditions of delivery. However, should it arise that the control and maintenance procedures are not diligently followed, the warranty will become invalid.

3 TECHNICAL SPECIFICATIONS

3.1 General	Year of constructions (<i>month/year</i>)	:	See type plate on frame
	Dimensions	:	see <i>chapter 11.9 Dimensions</i> <i>page: 61</i>
	Capacity vacuum/water tank	:	800 l / 400 l
	Length and diameter HP hose	:	80 m
	Diameter	:	1/2" (NW13)
	Length suction hose	:	2 m
	Diameter suction reel hose	:	3"
	Oil hydraulic	:	HESTIA 46 order number: 71003500046
	Important!	:	Replace once a year!
	Capacity	:	±50 l
3.2 Pump	Type	:	Speck P45
	Number of plungers	:	3
	Number of valves	:	6
	Maximum pressure (p)	:	320 bar
	Maximum output	:	46 l/min.
	Weight (m)	:	50 kg
	Maximum water temperature (T)	:	60 °C
	Oil	:	GX 80W90
	Quantity	:	3,5 l
3.3 Vacuum pump	Type	:	SLS 54
	Oil	:	Vacumax 100 (71.002.000.100)
	Capacity Suction	:	-0,8 bar (relative)
	Capacity Pressure	:	0,49 bar (relative)
	Quantity carter	:	
3.4 Customer service	When ordering spare parts it is recommended to give the following numbers:		
	Machine number	:	8004002016222
	Article number	:	22110581000
	Follow number	:	vo64567

4 CONSTRUCTION

4.1 Vehicle

The suction unit contains the following main parts:

- | | | | |
|-----|--------------------------------|-----|---------------------------|
| 1. | High-pressure hose on reel | 19. | Water tank |
| 2. | Hose holder | 20. | Vacuum tank |
| 3. | Control box | 21. | Handle Suction or Press |
| 4. | Vacuum/manometer | 22. | Emergency stop |
| 5. | Hydraulic (speed) reel control | 23. | Clamping bolts |
| 6. | High-pressure (HP) valve | 24. | Water level indicator |
| 7. | Locking device swivel arm | 25. | Sight glass |
| 8. | Press valve | 26. | Suction filter |
| 9. | Suction valve | 27. | Flashing orange light |
| 10. | Pressure regulator | 28. | Supply pipe water tank |
| 11. | Hose guide | 29. | PTO Switch |
| 12. | Pressure gauge | 30. | Supply valve water filter |
| 13. | Syphon | 31. | Drain valve |
| 14. | Oil tank hydraulic system | 32. | Suction reel |
| 15. | Vacuum pump | 33. | Charger Riomote battery |
| 16. | High-pressure pump | 34. | Pulsatorsystem On/off |
| 17. | Water filter | 35. | Choice valve reel wind |
| 18. | Tool box | | |

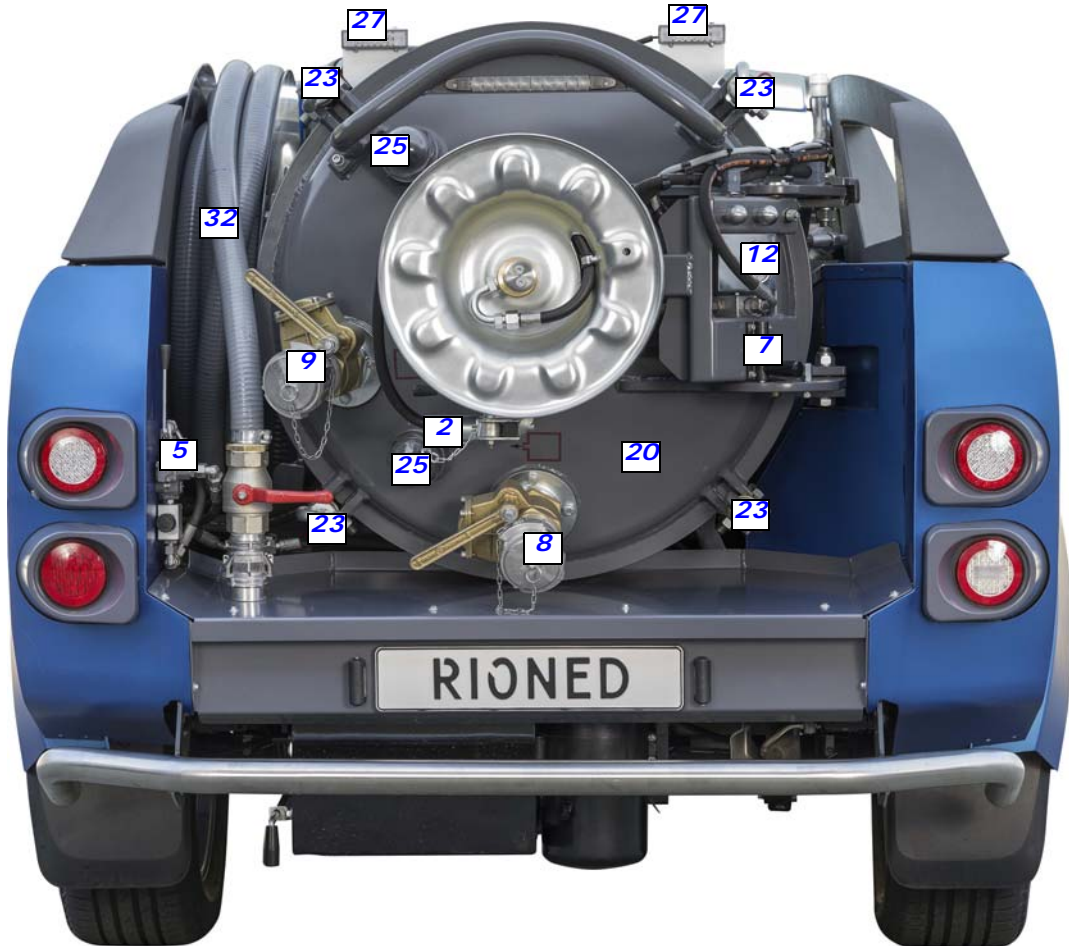

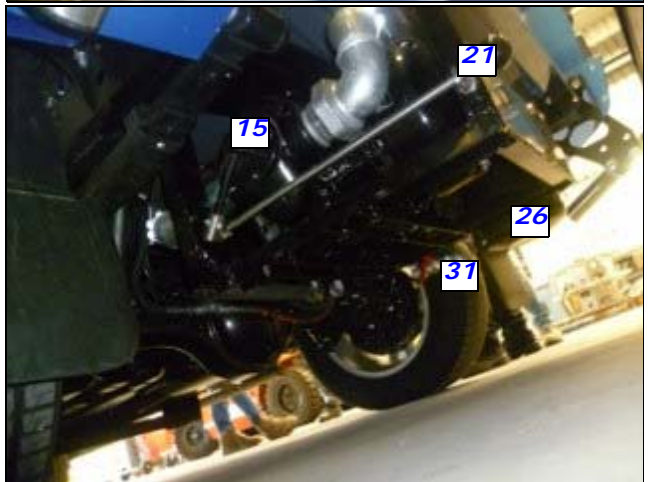

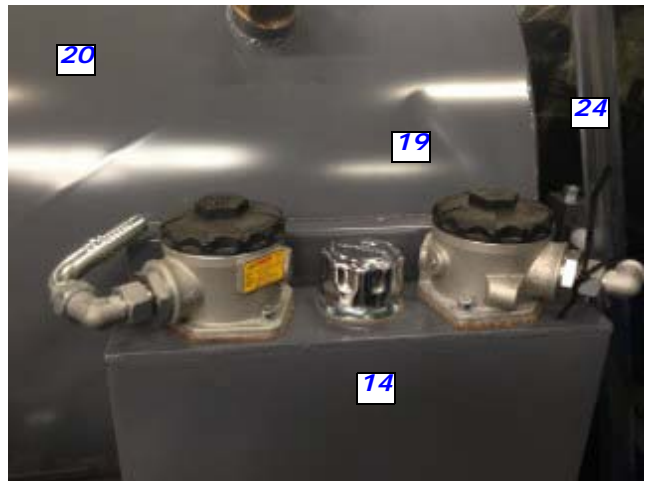
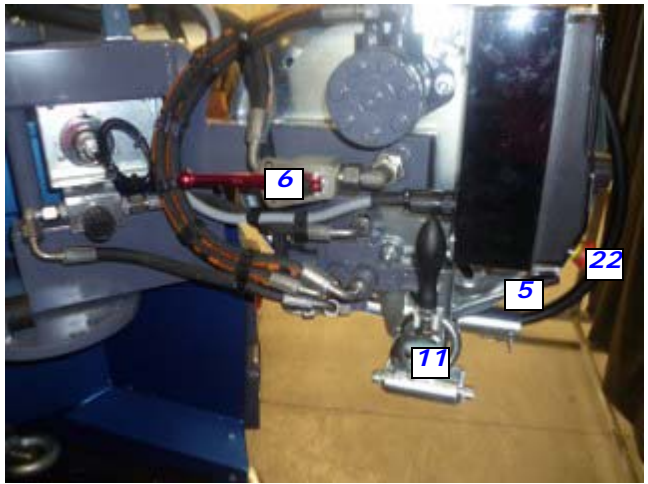

4.2 Control box

- | | | | |
|-----|--------------------|-----|--------------------------|
| 36. | Corona | 46. | High Pressure LED |
| 37. | Navigation bullets | 47. | High Pressure symbol |
| 38. | Function | 48. | Vacuum LED |
| 39. | Tachometer | 49. | Vacuum symbol |
| 40. | Pointer | 50. | Navigator |
| 41. | ECO Mode | 51. | Emergency Stop |
| 42. | Icons Left | 52. | Key (Off-Manual-Riomote) |
| 43. | Icons Right | | |
| 44. | Engine LED | | |
| 45. | Engine symbol | | |

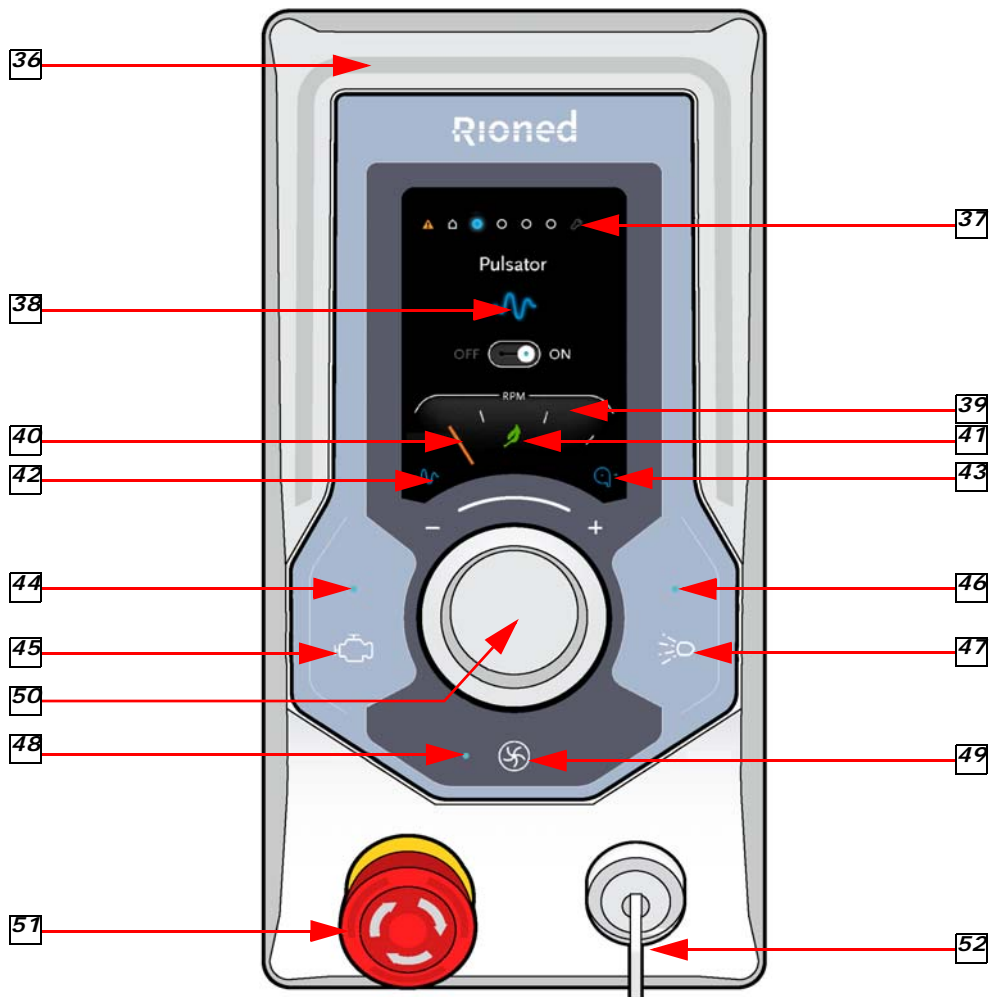

4.3 Corona

The Corona is OFF (grey)

unless:

- The Control Unit is:



Set to Riomote Control



Error applicable



Diesel engine Pre Heat,
Run dry
or
error Oil level

Switched OFF by the Eco Start/
Stop-system



5 CONTROL



Emergency stop:

The machine is equipped with an emergency stop. By operating this stop the machine will stop immediately. Do not use the button for normal stopping. Only use when dangerous situations occur. After use, turn the emergency stop in order to be able to start up again. Make sure the emergency stop can always be reached.



5.1 Before starting

1. Check the oil level in the high-pressure pump (**16**), vacuum pump (**15**) and oil tank (**14**) using the dipsticks and level indicator. Add oil, if necessary; see chapter "Maintenance".
2. Check whether the water filter (**17**) is clean. Clean the filter, if necessary; see chapter "Maintenance".
3. Check whether the high-pressure valve (**6**) on the reel is closed.
4. Check whether the supply valve (**30**) to the water filter (**17**) has been opened.
5. Check whether the drain valve (**31**) is closed.
6. Fill the water tank via the supply pipe (**28**).

The maximum water temperature is 60°C

7. Loosen the control wheel of the pressure regulator (**31**).
8. Screw the appropriate attachment onto the high-pressure hose.
 - a. Unclogging of a drain: jet nozzle

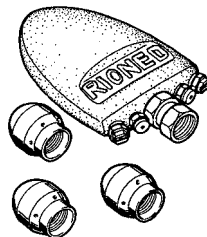

b Cleaning a wall, a terrace or floor: spray lance gun

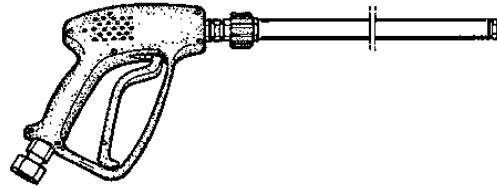

5.2 Starting the engine in the cabine:

1. Start the engine of the vehicle as usual. Do not start the engine longer than 10 seconds!
2. Hand break on.
3. Clutch pedal in
4. Put the car in 5th gear.
5. Turn the switch on to put the machine after 6 seconds into the Power Take Off.





(Between the chairs in the cabin)
Green light activates



6. Release the clutch-pedal. Engine shuts down.

5.3 Starting the engine at the back of the unit:

Position key control box (3):

- Insert key: 
- Position 1 (manual control): 
- Position 2 (remote control): 

5.3.1 Start diesel engine manually:

1. Put the key into the keyhole.
2. Turn the key to position 1 "Manual Control ON".



- "Work safe" is displayed for 2 seconds.
 - Icon "Manual control ON" is displayed for 2 seconds.
 - Then the main menu is displayed
 - ECO mode is standard always active if option "ECO Start/ Stop" or "ECO Stop" is available.
(see chapter 8.1 ECO mode OFF page: 35)
3. Check the error icon.
If the error icon is visible, then go to See "Errors eControl" on page 47..
Go further if the error icon is not visible.
 4. Push the engine button (45) 2 seconds.

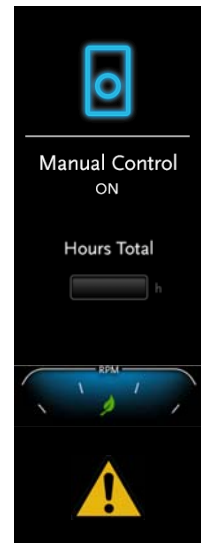

- "Pre Heat" and "Corona-orange" lightens for 5 seconds
- Engine starts
- When the engine runs the "Engine LED" (44) lightens blue
- "Engine ON" is displayed for 2 seconds.

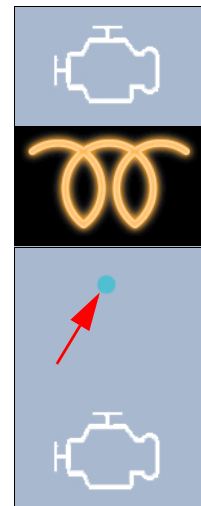

- Then the main menu is displayed
- 5. Increase (+ clockwise) or decrease (- counterclockwise) RPM by turning the Navigator (50).
- 6. Push the Navigator (50) for "Navigation bullet" menu.

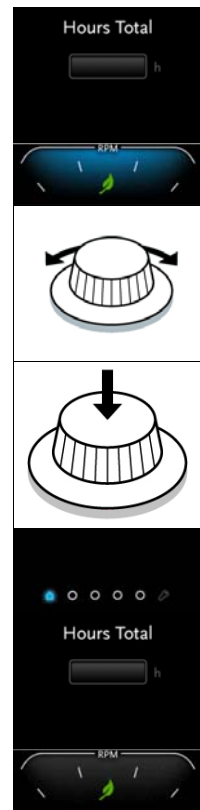

5.3.2 Start diesel engine via Riomote:

1. Put the key into the keyhole.
2. Turn the key to position 2 "Radio Control ON".



- "Work safe" is displayed for 2 seconds. (under construction!)



- Icon "Riomote control ON" displayed continuously.

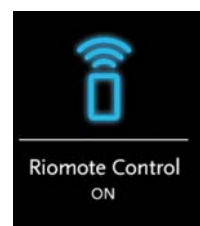

- Corona is coloured blue and is blinking.
(see chapter 4.3 Corona page: 20)
- 3. Switch on the Riomote control
(see chapter 8.3 Riomote Control page: 38)
- Corona is coloured blue continuously when the Riomote remote control has contact with the receiver.



If the Riomote Remote Control is not switched on in 10 seconds or has no contact, the corona colours red and the emergency stop activates.



- It is still possible to connect after 10 seconds if the Riomote remote control is switched on. Corona red disappears and the Corona colours blue.
- 4. Check the error icon for problems.
If the error icon is visible, then go to See "Errors eControl" on page 47..
Go further if the error icon is not visible.
- 5. Remove, for safety, the key from the control box.

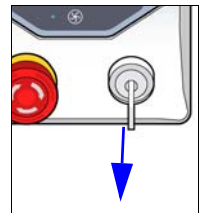

- 6. Push the "Engine start" button (6) on the Riomote.
(see chapter 8.3 Riomote Control page: 38)
• "Pre Heat" and "Corona-orange" lightens for 5 seconds
• Engine starts

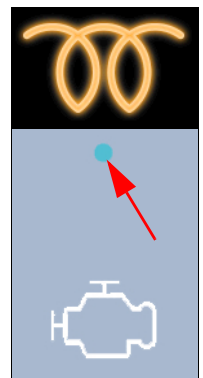

- When the engine runs the "Engine LED" (44) lightens
- 7. Increase RPM by pushing button (2).
(see chapter 8.3 Riomote Control page: 38)

5.4 Unclogging a drain

1. Screw a suitable nozzle onto the high-pressure hose.
2. Unwind the hose. (see chapter 8.5 Hydraulic reel control page: 42)
3. Put the nozzle into the drain that is to be cleaned.
4. Open the high-pressure valve (6) near the HP reel manually.
5. Screw the high-pressure regulator (10) fully open (right).

5.4.1 Start spraying:

By eControl:

1. Press button "High Pressure ON" (47)
 - Water sprays out of the nozzle at the end of the hose.
 - "High Pressure LED" (44) lightens blue.
 - "High Pressure" on display for 2 seconds.
- Then the main menu is displayed after 5 seconds.
2. Increase or decrease RPM by turning the Navigator.

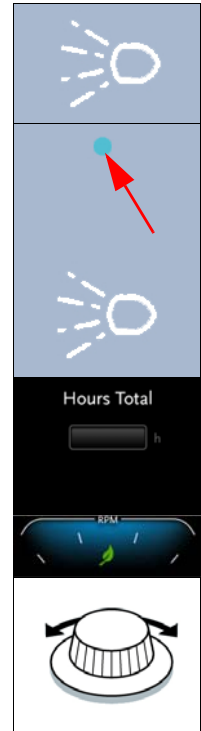

Via Riomote Control

(see chapter 8.3 Riomote Control page: 38):

1. Press button 4 (Start spraying).
2. Press button 2 (Throttle up).

The hose will now unwind and work its way into the drain.

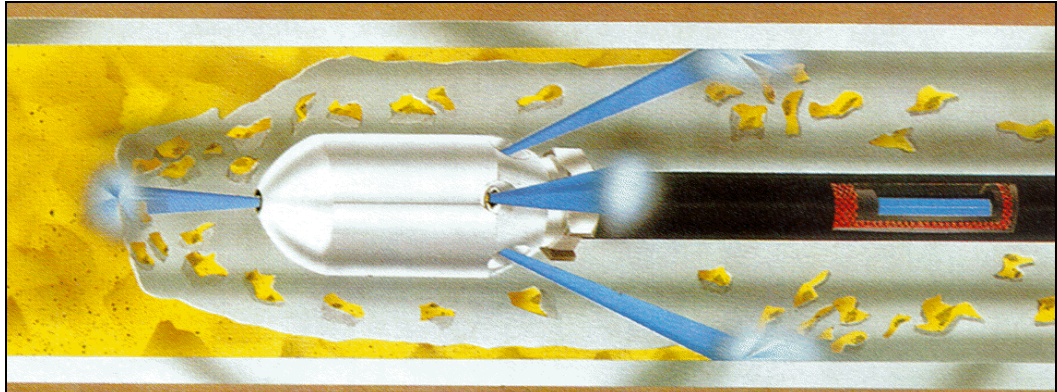

3. Check that the water drains away. When the blockage has been cleared, continue to flush for a while. At the same time wind the hose up slowly.



Important!

Rewind hose onto reel under pressure to avoid crushing.
If machine has run out of water, ensure hose is unwound before pressurizing.

5.4.2 Stop spraying:

By eControl:

1. Press button "High Pressure OFF" (47)



- "High Pressure LED" extinguishes.
- "High Pressure OFF" on display for 2 seconds.
- Water stops spraying out of the nozzle at the end of the hose.
- Engine RPM decreases.

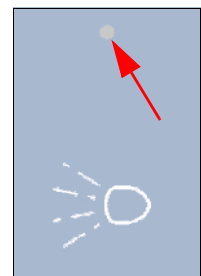

Via Riomote Control

(see chapter 8.3 Riomote Control page: 38):

1. Press button 3 (Stop spraying) on the Riomote Control.
- "High Pressure LED" extinguishes.
- Water stops spraying out of the nozzle at the end of the hose.
- Engine RPM decreases.

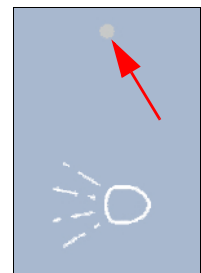

Treat the high-pressure hose carefully:

- Always clean it after use.
- Ensure that no sharp objects are near the hose.
- Ensure that no traffic crosses the hose.
- If the hose has to be repaired, use only the special repair couplings.



Attention!

Ensure that the spraying nozzle does not leave the drain! Water under high-pressure may cause severe injuries!



5.5 Cleaning a wall, terrace or floor.



Caution!

Before using a spray gun, you must always set the pressure below the maximum (\pm the half of the maximum pressure). You must do this before you start the machine. If the machine is running, the pressure can be increased by turning the control wheel towards it's maximum working pressure. Never exceed the maximum pressure that is marked on the manometer when using the spray gun.

1. Screw the spray gun onto the high-pressure hose. Fasten it by using the two spanners provided.
2. COMPLETELY unroll the high-pressure hose (see chapter 8.5 Hydraulic reel control page: 42).
3. Open the HP valve near the HP reel.

Start spraying by eControl:

1. Press button "High Pressure ON" (47)



2. Throttle up via:
 - Turning the Navigator (50) clockwise (Diesel version).
 - Push button 2 on the Riomote control.
3. Screw the high-pressure regulator wheel upward on the high-pressure regulator until the required working pressure is reached. The adjusted pressure can be read from the pressure gauge (12) on the machine when the spray gun is open.
4. Pull the trigger of the spray gun.

Stop spraying

Release the trigger of the spray gun.

5.6 Stop working

1. HP pump off and throttle down:
 - a Press button "Stop spraying"
 - b Push button 3 on the Riomote Control.
2. Close the HP valve near the HP reel.
3. Stop the engine:
 - a Push button "Engine ON" for more then 1 second
 - b Push button 5 on the Riomote Control.
4. Check that the water drains away. When the blockage has been cleared, continue to flush for a while. At the same time wind the hose up slowly.

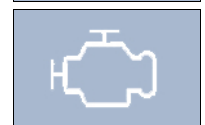

5.7 PTO OFF

- Foot brake in
- Hand brake off
- Push the clutch pedal
- Switch with button the PTO to position "off".



- Neutral gear
- Release the clutch pedal.

Now you can drive with the vehicle.

5.8 Using the device during periods of frost (no option antifreeze tank available)

Your machine may freeze up during a period of frost. A number of safety precautions must be taken.

Additional preparations before departure:

1. Drain the water tank and the water filter.
2. Close the drain valve and mount the filter again.
3. Put enough antifreeze into the water tank.
4. Open the high-pressure valve.
5. Start the machine and let it run.
Note: it is not necessary to attach either a nozzle or a gun to the high-pressure control.
6. Let the high-pressure pump remove all the water, which is still in the high-pressure hose.
7. Close the high-pressure valve when anti freeze come out of the hose.
8. Leave the engine running for some time: to allow all pipes to fill up with antifreeze.
9. Switch off the machine.

Now the machine is ready for departure!

5.9 Additional preparations when preparing for use:

1. Turn on the machine and let the high-pressure pump drain all anti-freeze into a jerry can. The antifreeze can be reused. Ensure that no water is mixed with the antifreeze. If water gets into the antifreeze, it is not suitable for re-use. Dispose the used antifreeze properly, hand it into a local depot for disposal of industrial waste.
2. Stop the machine and prepare it for use.

6 USING THE VACUUM DEVICE



It is forbidden to drive with a vacuum tank and water tank that is completely full when the maximum allowed load is overstepped. Before you are going to drive, one of the two tanks must always be empty.

Use the vacuum system only for cleaning sewers and tanks (see chapter 1 Introduction page: 7).

6.1 Before use:

1. Close the suction valve (9) and press valve (8).
2. Clean the siphon (13).
3. Check regularly if the inside siphon is clean. Clean it if dirty.
4. Check the oil level of the vacuum pump (15).
5. Check if the vacuum tank cover is closed and all bolts (23) are tightened.
6. Fasten the suction hose at the suction valve (9) or use the suction reel.

6.2 Fill the dirt water tank:

1. Put the end of the suction hose into the dirt.

By eControl:

2. Press button "Vacuum ON"
 - "Vacuum LED" lightens blue.
 - Then the main menu is displayed after 5 seconds.
3. Increase or decrease RPM by turning the Navigator.

Via Riomote Control:

1. Press button 7 (Vacuum ON).
2. Press button 2 (Throttle up).
3. Check the vacuum/manometer (4) (max. -0,8 bar).
4. Open the suction valve (9).

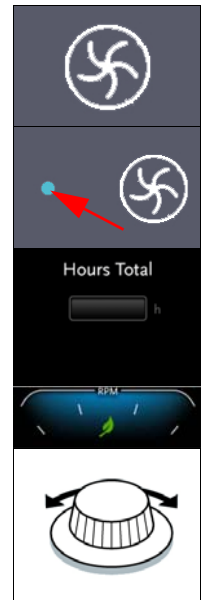



Caution!

The vacuum pump is protected against overheating and will be shut off automatically.

6.2.1 Stop vacuum:

By eControl:

1. Press button "*Vacuum OFF*"



- "*Vacuum LED*" extinguishes.
- Engine RPM decreases¹.



Via Riomote Control:

1. Press button **8** (*Vacuum OFF*) on the Riomote Control.
- "*Vacuum LED*" extinguishes.
- Engine RPM decreases.



6.3 Empty the dirt water tank:

1. Fasten a suction hose onto the press valve (**8**).
2. Place the end of the suction hose where the substance must come out.
3. Open the press valve.
4. Press button "*Vacuum ON*"



5. Increase or decrease RPM by turning the Navigator.

Let the vacuum pump press all the dirt out of the tank (max. 0.5 bar.)

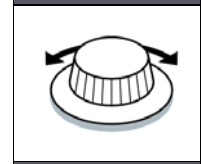

6. Press button "*Vacuum OFF*"



7. Open the suction valve (**9**) for remaining pressure.
8. Open the tank cover.
9. Clean the vacuum tank.
10. Check the float ball protection in the vacuum tank (dirt and functioning).
11. Close the tank cover.

¹. Engine does not decrease RPM when "High pressure ON" is activated.

7 SYMBOLS

7.1 Pressure gauge

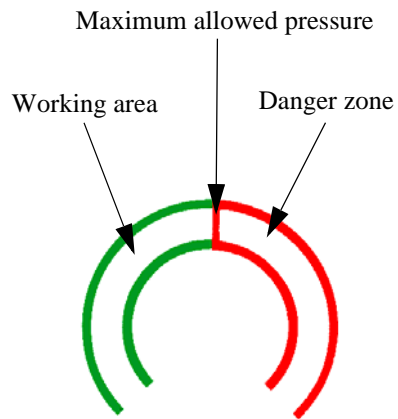

7.2 Pressure regulator

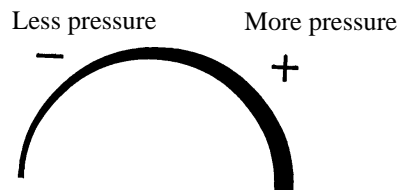

7.3 Valve control

Open and close valve:

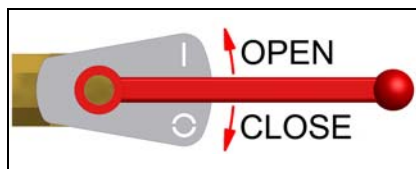

7.4 Security sticker

1. Gehör- Kopf- und Augen Schutz tragen verpflichtet.
2. Sicherheitsschuhe mit extra Schutz verpflichtet.
3. Betriebsanleitung studieren verpflichtet.
4. Sicherheitshandschuhe mit Pulsschutz verpflichtet.
5. Schutzkleidung verpflichtet.
6. Kein Trinkwasser.
7. Gefahr für rutschen.
8. Pas auf für Handverletzung.
9. Drehende Maschine.
10. Achtung für automatische anlassende Maschine.

1. You must wear ear- head- and eye protection.
2. You must wear security shoes with extra protection.
3. Read the user's manual.
4. You must wear safety gloves with wrist protection.
5. You must wear protection cloth.
6. No drinking water.
7. Slip danger.
8. Look out for hand damage.
9. Turning machine.
10. Warning for automatically starting machine.

1. Gehoor- hoofd- en oogbescherming dragen verplicht.
2. Veiligheidsschoenen met extra bescherming verplicht.
3. Handleiding lezen verplicht.
4. Veiligheidshandschoenen met polsbescherming verplicht.
5. Beschermende werkkleding verplicht.
6. Geen drinkwater.
7. Gevaar voor uitglijden.
8. Pas op voor handletsel.
9. Draaiende machine.
10. Waarschuwing voor automatisch startende machine.

1. Protection obligatoire des yeux, de l'ouïe et de la tête.
2. Protection obligatoire des pieds.
3. Obligation de lire le manuel d'utilisation.
4. Protection obligatoire des mains.
5. Protection obligatoire du corps.
6. Eau non potable.
7. Attention Risque de sol glissant.
8. Attention Risque d'écrasement.
9. Attention Risque de dangers divers.
10. Attention Risque de démarrage automatique a tous moments.



8 Options

8.1 ECO mode OFF

To change the ECO mode, the engine must run!

ECO mode is standard always ON if function is available on machine.

1. Turn the Navigator (15) clockwise and set the navigation bullet to position 5 "Eco Mode".

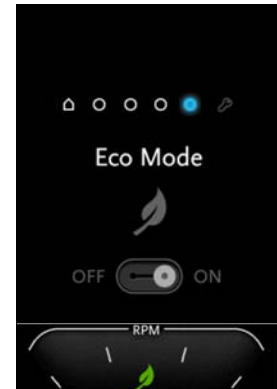

2. Push the Navigator (15) to activate the function.

- Navigation bullet extinguishes.
- Eco Mode icon lightens green.

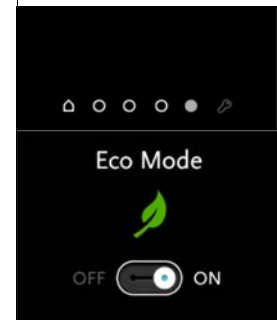
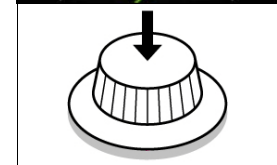

3. Turn the Navigator (15) counterclockwise.

- Eco Mode is "OFF".

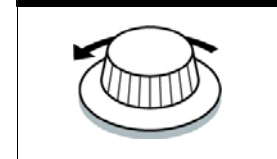

4. Push the Navigator (15) to deactivate the function.

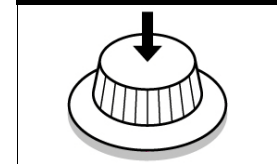
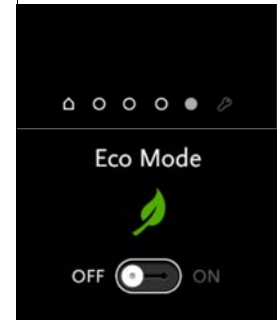

- "Eco Mode" icon extinguishes
- Navigation bullet lightens blue

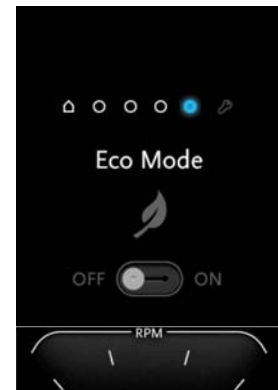

- "Eco Mode" icon  disappears

5. Wait 2 seconds!
- "Hours Total" is displayed.

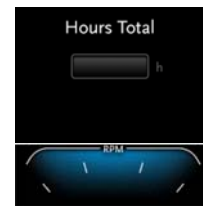

8.2 ECO versions

The ECO mode has two versions:

1. ECO Start/Stop
2. ECO Stop

8.2.1 ECO Start/Stop behaviour:

Stop:

- Press "High pressure OFF":
 - a Water stops spraying
 - b RPM engine decreases.
 - c Engine stops after 30 seconds if no activity takes place.

Start:

- Press "High pressure ON":
 - a Engine starts, if necessary.
 - b Water comes out of the HP hose.
- Increase RPM for more pressure and water.

or

- Press "Engine Start".
- Press "High pressure ON"
 - a Water comes out of the HP hose.
- Increase RPM for more pressure and water.

8.2.2 ECO Stop behaviour:

Stop:

- Press "High pressure OFF":
 - a Water stops spraying
 - b RPM engine decreases.
 - c Engine stops after 30 seconds if no activity takes place.

Start:

- Press "Engine Start".
- Press "High pressure ON"
 - a Water comes out of the HP hose.
- Increase RPM for more pressure and water.

8.3 Riomote Control

Purpose: To operate the high-pressure machine from a distance.

8.3.1 Emergency stop test

Check before working with the Riomote Control if the emergency stop works well. Proceed as follows:

1. Put the key into the keyhole.
2. Turn the key to position 2 "Radio Control ON".



- "Work safe" is displayed for 2 seconds. (only diesel version (under construction!))



- Icon "Riomote control ON" displayed continuously. (only diesel version)

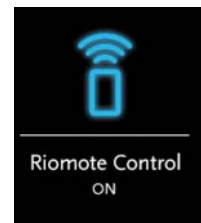

- Corona is coloured blue and is blinking. (only diesel version) (see chapter 3.1 Corona page: 10)

- Switch the Riomote Control on



- Press until corona stops blinking.
- Corona is coloured blue continuously when the Riomote control has contact with the receiver (only diesel version).

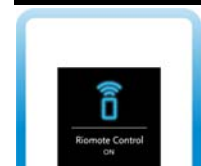



- Start the engine¹ by means of button “START”

- Push the “STOP” button



The machine has to cut off now.



If this is **not** the case it is **not** allowed to work with the Riomote Control. Contact your supplier.

8.3.2 Battery

If the indication  on the Riomote Control starts burning it's indicates that the battery must be changed with a new fully loaded battery.

If the battery isn't changed the Riomote Control switches off in a short time.

Reload empty batteries.



The function buttons on the transmitter can be different as shown in the next paragraphs!
Look at the symbols on the transmitter for the actual functions!

1. not with 5 channel Riomote

8.3.3 Functions 9 channel Riomote Control:

1. Throttle down
2. Throttle up
3. Stop spraying
4. Start spraying
5. Stop the engine
6. Start the engine
7. Vacuum pump On
8. Vacuum pump Off
9. Emergency stop



8.4 Management

1. Turn the Navigator (**15**) clockwise and set the navigation bullet to position 6 "Management".
2. Push the Navigator (**15**) to activate the function.
 - Navigation bullet extinguishes.
 - Management underline lightens.
 1. Software version.
 - Press Navigator shows actual software settings
 - Press again Navigator to leave this menu. (Scroll down)
 2. Service interval
 - Press Navigator shows actual:
 - a days till service.
 - b hours till service.
 - Press Navigator again to leave this menu.

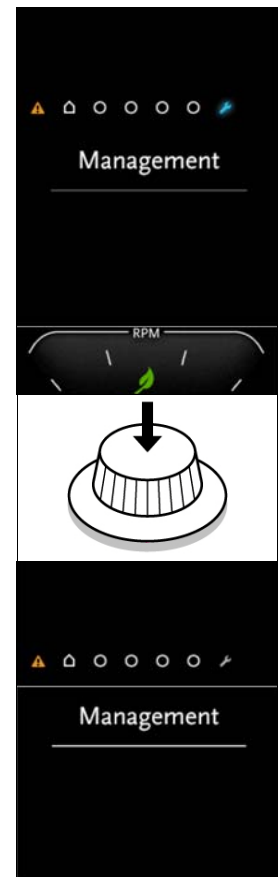

Scroll to "Back" and press on Navigator to go back to the navigation bullets.

8.5 Hydraulic reel control

First choose the reel you want to wind (14).

By means of using the control lever the high-pressure hose can be unrolled or rolled up. Due to the proportional functioning of this valve you can also control the speed of the reel. By putting the lever into position manual, you can unroll the hose manually.



Attention! Never block the lever and always control it with one hand while guiding the highpressure hose by means of the hose guide with the other hand to the required place.

Functions:

Handle:

- A Wind the hose
- B Reel locked
- C Unwind the hose
- D Reel "out of gear"

Control wheel:

- E Reel rotates faster
- F Reel rotates slower

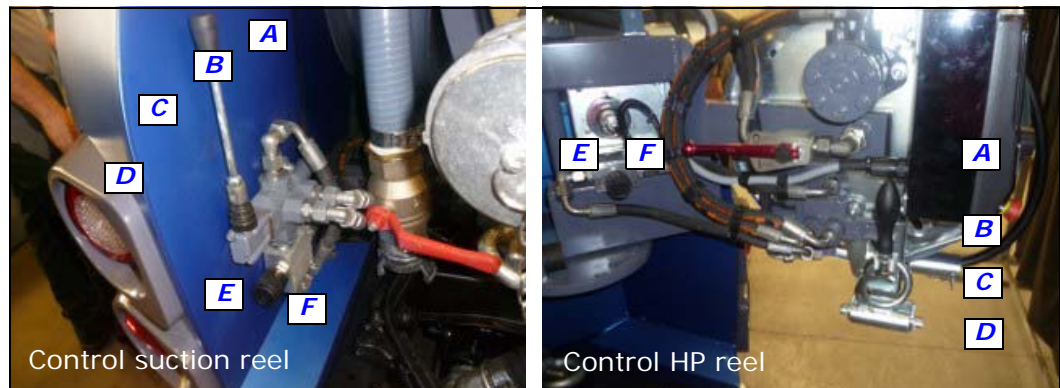

8.6 Run dry protection

The run-dry protection has the purpose to protect the high-pressure pump.

Functioning:

If the water level in the tank is too low, the run-dry protection activates.

Cancelling:

Fill the water tank. (Supply hose, Fill opening, Supply pipe...)

8.7 Flashing orange light

By means of switch



you can turn the working lamp ON and OFF.

7. Switch off the machine immediately in case no more antifreeze is pumped into the antifreeze tank.

8.8 Hose guide

Purpose:

To guide safely the HP hose into the sewer.

To wind the HP hose safely on the reel drum.

Use:

- Put the end of the hose through the opening of the hose guide.
- By moving the hose guide to the right and left, you can wind the HP hose fluently on the reel drum.
- After use, lock the support.

Advantage

- No dirty hands
- Hose lives longer
- More freedom of movement
- Security
- Hose stays cleaner.

9 MAINTENANCE



Attention!

Always stop the engine first and depressurize the system before serving or repairing the machine.

To depressurize the system, you open the HP valve. If the spray lance gun is attached you must also pull the trigger.

9.1 Daily maintenance

1. Oil level

Check all oil levels once a week. Add oil, if necessary.

If an oil level has dropped, this implies a leak in the system. In which case, check all gaskets, couplings, and (hydraulic) pipes in the system. Immediately repair damage and fill the system with the correct oil.

Note!

During the settling-in period, the oil consumption can be more than usually.

2. Cleaning water filter:

- a Close the supply valve in the suction pipe.
- b Unscrew cap from the filter piece.
- c Clean the filter and concerning parts.
- d After cleaning, assemble the parts in opposite order.
- e Open supply valve.
- f Check for leakage.

9.2 Weekly maintenance

1. Cleaning:

Clean the carriage weekly. Use car shampoo and plenty of water.

9.3 Minor servicing

Minor servicing must be carried out EVERY 250 WORKING HOURS (or at least once every 6 months) and includes the following parts of the machine:

1. Carriage:

Lubricate all mechanical moving parts in the system. Check that all nuts and bolts have been correctly tightened.

2. Pump system

- Cleaning the high-pressure control:

When the high-pressure valve has been closed, the pressure gauge should not indicate any pressure. Similarly, if the spray gun is connected and closed, the pressure gauge should not indicate any pressure. If the pressure gauge does indicate a pressure, this implies a leakage in the system or that the one-way valve may be dirty or damaged. In

which case stop the machine, unscrew the hose coupling and clean or replace the one-way valve. Also, check the condition of the O-ring and gasket.

Regularly clean the high-pressure control. Carefully remove all dirt! Proper maintenance will increase the service life of this part.

- Changing the pump oil:
Change the pump oil in the high-pressure pump after every 1000 working hours (or at least once a year).

For more information concerning the pump, you can find it in the enclosure delivered with this machine.

9.4 Hydraulic system

Renew oil



Important!

You have to renew the hydraulic oil at least ones a year!

Only use oil: *see chapter3.1 "General" page.: 13*

Check, every time before use, if the level of the oil is sufficient.

Proceed as follows:

1. Stop the machine.
2. Be aware that the machine is standing horizontal.
3. Take the dipstick out of the oil tank.
4. Clean the dipstick with a tissue.
5. Put the dipstick into the oil tank.
6. Take the dipstick back and watch at the dipstick if the oil is between maximum a minimum.
7. Fill oil, if necessary.
8. Fasten the dipstick onto the oil tank.
9. Start the engine and let it turn for about 5 minutes.
10. Stop the machine and repeat point 2 until 8.

9.5 Clean the vacuum tank

Before cleaning the dirt water tank always drain the tank.

1. Open the back cover, unscrew the clamping bolts;
2. Clean the vacuum tank;
3. Clean all pipes;
4. Clean the float ball;
5. Close the cover.

9.6 Maintenance vacuum pump

See the manual of the vacuum pump delivered with this machine!

9.7 Cleaning the suction filter

Clean the suction filter every time before use.

Remove the cap below and remove all dirt and liquids.



9.8 Cleaning the siphon

Drain the siphon before use.
Or see sight glass when necessary.



9.9 Extensive periodical maintenance

Have the high-pressure machine checked and maintained from time to time by the technical service of Rioned. In this way, long life and quality will be guaranteed.

9.10 Maintenance scheme

Interval

Valve actuator	:	Replace every 250 working hours
Check oil levels	:	Every time before use
Cleaning water filter	:	Every time before use and with strong pollution.
Cleaning carriage	:	weekly or with strong pollution.
Lubricate moving parts	:	Every 250 working hours or at least once every six month
Cleaning pressure regulator	:	Every 250 working hours or at least once every six month
Renew HP pump oil	:	Every 1000 working hours or once a year
Renew oil hydraulic system	:	Once a year
Decalcify suction valves	:	Once a year
Decalcify pressure valves	:	Once a year
Puncture nozzle holes	:	Every 50 working hours

Replace all parts immediately if there is wastage or defect.

10 TROUBLESHOOTING

Failure	Reason	Solution
The high-pressure pump does not produce the required pressure.	Water tank empty	Fill the water tank
	Supply valve to water filter closed.	Open the supply valve
	Water filter clogged.	Stop the machine and clean the water filter
	Air in high-pressure pump	Allow the machine to run a few minutes. The failure will normally disappear. If not, contact the service department of your dealer
	Suction valves blocked	Carefully loosen the valves and descale them, if necessary
	Suction valves worn out.	Contact the service department of your dealer.
Pressure varies.	Water level in tank too low	Stop the engine, refill the tank and restart engine
	Water supply valve not sufficiently opened	Open the supply valve completely
	Water filter clogged.	Stop the machine and clean the filter
	Pump sucks air	Stop the machine and check all hoses and couplings for leakage
	Nozzle clogged	Stop the machine and clean the nozzle (clean the nozzle holes)
	Pressure valves dirty or worn	Stop the machine. Check the condition of the pressure valves. Clean or replace them
	Pump gasket worn out	Stop the machine and replace gasket
	Ceramic plungers in the pump damaged	Contact your dealer
	Pressure control clogged or internally damaged.	Contact your dealer.

Failure	Reason	Solution
Hydraulic reel does not wind the hose	Handle not on right position	Put the handle into the right position
	Hydraulic tank almost empty	Refill the tank. Check the system on leakage
	Drive chain not sufficiently tightened	Tighten the chain
	Attachment bolt for control lever of hydraulic system loosened	Fasten the bolt and put the lever into the correct position
	Working pressure set too low	Increase the working pressure, if possible
	Return filter hydraulic tank dirty	Switch off the machine and clean the return filter
	Hydraulic system damaged	Contact your dealer
No suction of the vacuum pump	Switch doesn't supply current to magnet coupling	Contact your dealer
	Magnet coupling doesn't work	Contact your dealer
	Vacuum valve or press valve in open position	Close the valve
	Lever vacuum valve suction/pressure in wrong position	Put the lever in the right position
	Clamp bolts not well-fastened	Fasten the bolts
	Float ball protection dirty or stacked	Clean or loose the ball
	Still pressure in tank	Open the vacuum valve
	Oil separator not drained	Drain the oil separator
	Oil in the pump	Press, at low speed of revolution, the oil out of the pump
	Vacuum pump too hot or not greased sufficiently and blades of the pump stuck or burned	Contact your dealer
	Bad cleanness of float ball protection	Clean again and press out the dirt, if necessary.
	Dirt reached the pump and blades stuck off.	Contact your dealer.
No reaction by switching in transmitter	No current	Load battery
		Use new battery
		Control contact points on dirt and dust
		Check fuses
		Contact your supplier by repeating disturbances
	Transmitter is not on	Put button 0/1 to position I
	Transmitter out of reach from receiver	Put the machines closer on. Put transmitter closer

Failure	Reason	Solution
Warning signal after short working time	Battery empty / defect	Load or replace
	Battery not loaded or defect	Charge battery complete Check if the plug is connected and if the contact is on.
		Check if the charging works well
		Check battery points / clean it
		Use other battery
Transmitter indications are good but functions are not executed	Emergency stop pushed in	Unlock emergency stop
	Receiver has no current	Check / replace fuses
	No radio connection	Check functions of control lights
Certain functions are not executed	Receiver is faulty	Contact your supplier
	Interruption in electric circuit	Check all plugs. Plug in and push.
		Check control lights if functions are indicated

11 EXPLODED VIEWS AND SPARE PARTS LISTS

11.1 Pressure regulator (ULH261).

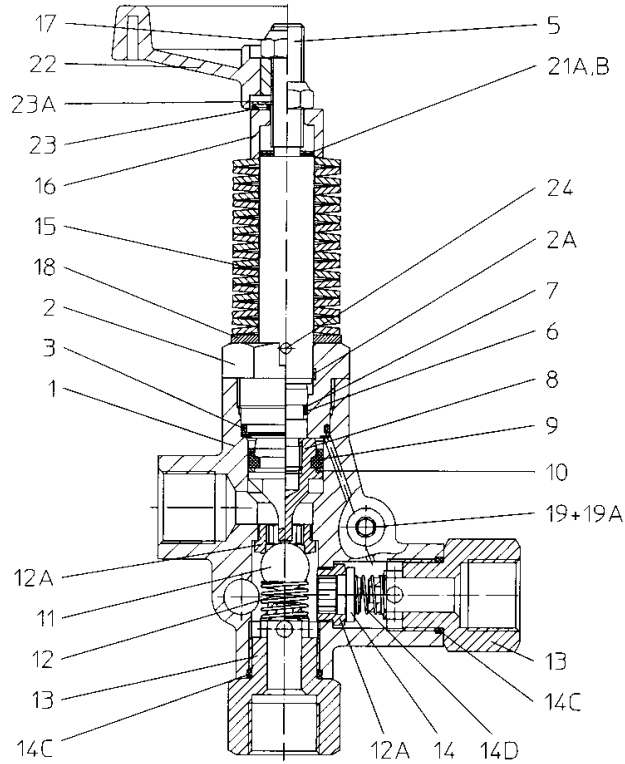

Item No.	Qty	Order number	Factory No.	Description
1	1	67-262-101-001	01-0630	Casing
2	1	67-262-101-002	07-2788	Guide Plug
* 2A	1	67-262-101-102	06-1131	Guide ring
* 3	1	67-262-101-003	06-0255	O-Ring
5	1	67-262-101-005	11-0477	Piston Rod
* 6	1	67-262-101-006	06-1129	O-Ring for 5
* 7	1	67-262-101-007	00-6113	Support Ring for 6
8	1	67-262-101-008	07-1064	Piston Body
* 9	1	67-262-101-009	06-0071	Sleeve
* 10	1	67-262-101-010	07-0591	Sleeve Support Ring
* 11	1	67-262-101-011	07-1920	Ball
* 12	1	67-262-101-012	07-0637	Spring for Bypass Valve
* 12A	2	67-262-101-112	07-1061	Valve Body
13	2	67-262-101-013	07-3006	Valve Plug
* 14	1	67-262-101-014	07-3005	Valve Plate
* 14C	2	67-262-101-314	06-0496	O-Ring
* 14D	1	67-262-101-414	07-1941	Spring for Kick-Back Valve
15	21	67-262-101-015	07-1662	Spring Plate 120 bar
15	19	67-262-101-015	07-1523	Spring Plate 280 bar
15	23	67-262-101-015	07-2899	Spring Plate 40 bar
16	1	67-262-101-016	07-2167	Spacer Sleeve
17	1	67-262-101-017	07-2165	Hexagon Nut Self Locking
18	1	67-262-101-018	07-1076	Disc
19	4	67-262-101-019	07-1058	Plug
* 19A	4	67-262-101-119	06-0245	O-Ring for 19
21A		67-262-101-121	07-1792	Spacer Disc 0,5 mm
21 B		67-262-101-221	07-1793	Spacer Disc 1,0 mm
22	1	67-262-101-022	07-2166	Spoked Hand wheel ULH
23	1	67-262-101-023	05-0136	Axial needle Bearing ULH
23A	1	67-262-101-123	07-3432	Disc ULH
24	1	67-262-101-024	07-2164	Serrated Pin
*	1	67-262-101-025	14-0554	Repair Kit

11.2 Siphon

Parts List			
ITEM	QTY	PART NUMBER	DESCRIPTION
1	1	6045600060	VLOTTERBAL ROND 60
2	1	60456060061	GLAS SYPHON 60 MM
3	2	60456060062	O-RING SYPHON
4	1	60456060066	AANSLUITSTUK RECHT ROND 60 MM 21732 7/60
5	1	60456060067	AANSLUITSTUK BOCHT 60 MM
6	1	60456060068	SYPHON POT
7	1	60456060069	PLUG SYPHON ONDERZIJDE

Tenzij anders aangegeven zie Rioned normblad maaddelen en:		3.2 / 12.5	Hoeken en kanten breken.	Zetten: R inwendig =	Lineaire maten: (uitzondering laswerk: 0-150: ±0,5 150-2000: ±1)			
		0,5-6: ±0,1	6-30: ±0,2	30-120: ±0,3	120-400: ±0,5			
		400-1000: ±0,8	1000-2000: ±1,2	2000-4000: ±2,0				
Benaming: SYPHON 60 MM NIEUW MODEL				Datum: 5-12-2000	Materiaal:			
				Getek.: Ronald	Artikelnummer:			
				Gecontr.:	Behandeling:			
An Affiliate of Spartan Tool L.L.C. Rioned WWW.RIONED.COM		Centaurusweg 45, 5015 TC Tilburg Tel.: 013-5479100 Fax: 013-5479104		Blad 1 v. 1 bl.	Prod. no.: 60456060065			
Deze tekening is eigendom van Rior B.V. / Rioned en mag zonder haar toestemming niet verspreid worden, noch aan derden ter inzage gegeven worden.				Maten in mm A3	Tek. no.: 60456060065 /			
File: C:\Vautl\branses\Biblictheek\ Parts\60 Kamlock koppelingen\60456060065.sam								

12 APPENDIX

12.1 EC declaration Of Conformity For Machinery

RIOR B.V. / RIONED
Centaurusweg 45, Tilburg, The Netherlands,

Herewith declares that:

RIONED Urban Combi,

- is in compliance with the Machinery Directive (2006/42/EC);
- is in conformity with the provisions of the following other EEC directives:
2014/30/EG
- the following harmonized standards have been applied:
NEN-EN-ISO 12100:2010, NEN-EN-ISO 13850:2015,
NEN-EN-ISO 13857, NEN-EN-349, EN 60204-1

Tilburg, The Netherlands, Tuesday 15 November 2016

A handwritten signature in black ink, appearing to read 'J. Pieters', written over a horizontal line.

J. Pieters
Managing Director

12.2 Sales Managers

EXPORT

D. Maas / H. de Laat
Centaurusweg
5015 TC Tilburg
Tel.: +31 13-547 91 00

REPAIR

THE NETHERLANDS

Rioned
Centaurusweg 45
5015 TC Tilburg
Tel.: +31 13-547 91 00
Fax: +31 13-547 91 04

12.3 Electric plan

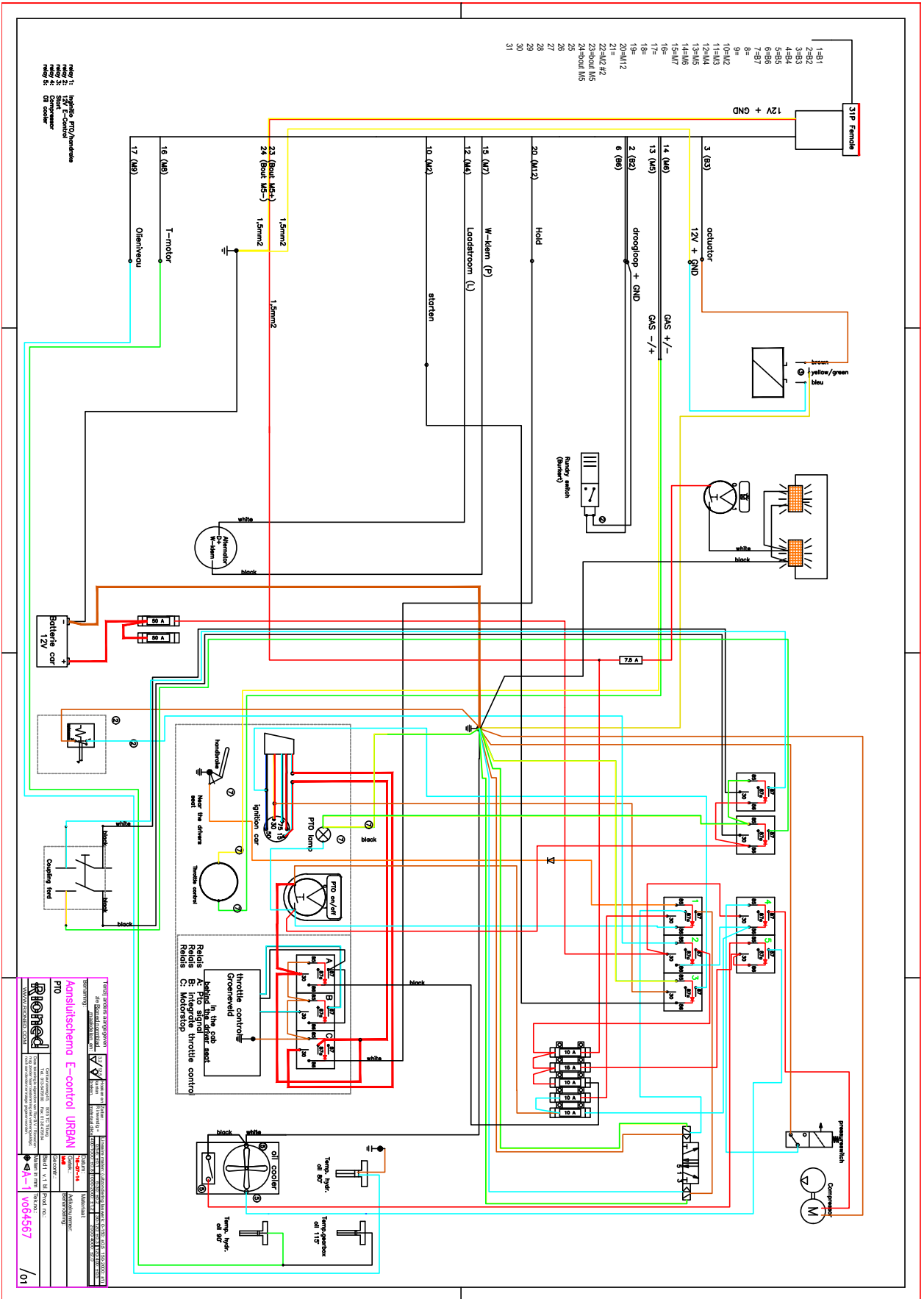

12.4 Electric plan

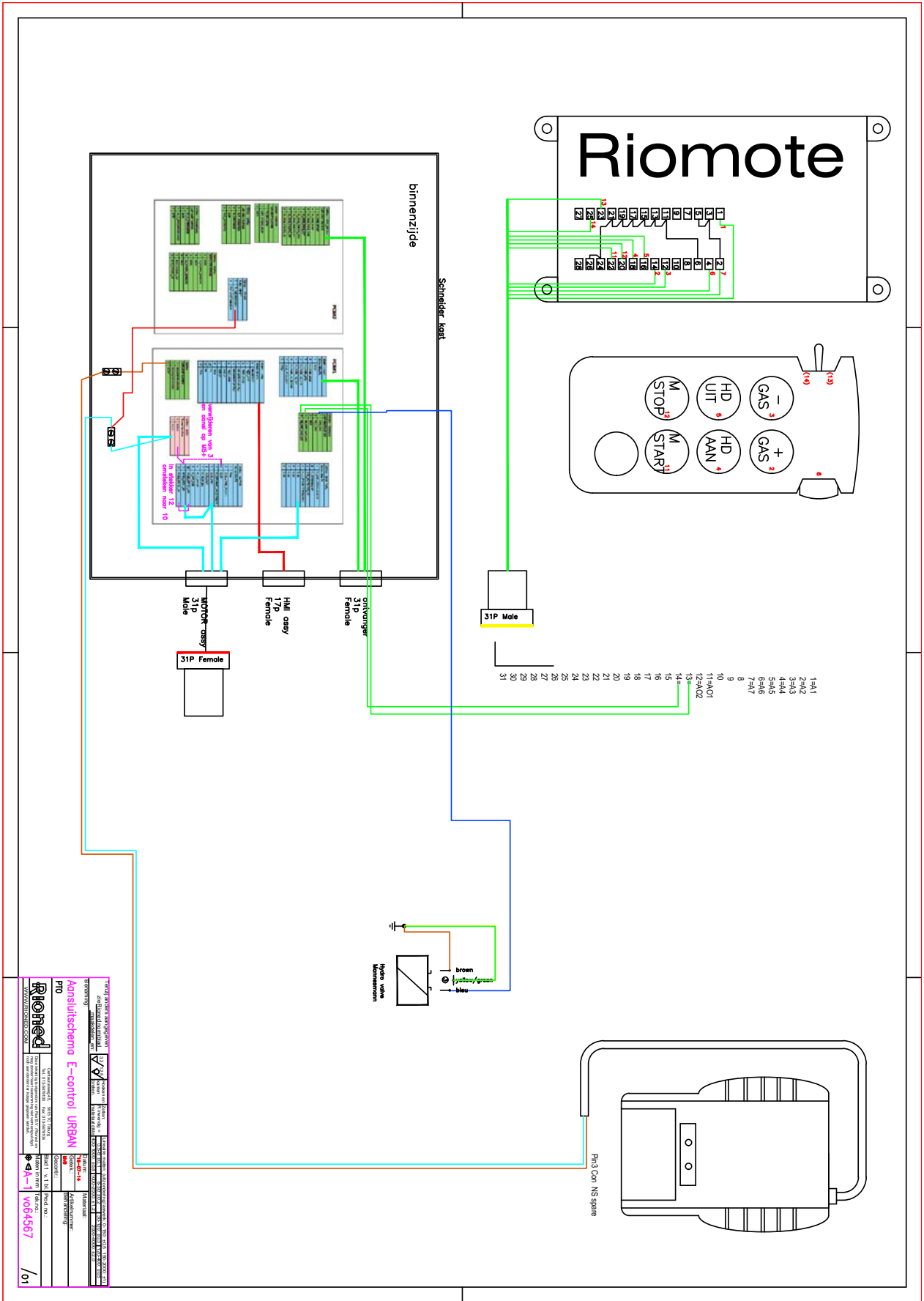

Riomote **Aansluitschema E-control URBAN**

Model: P70

Product No.: V064567

Version: /01

Manufacturer: Riomet

Address: Riomet, Industrieweg 1, 3143 AB, Rotterdam, The Netherlands

Phone: +31 (0) 20 467 1000

Website: www.riomet.nl

12.5 Switch plan

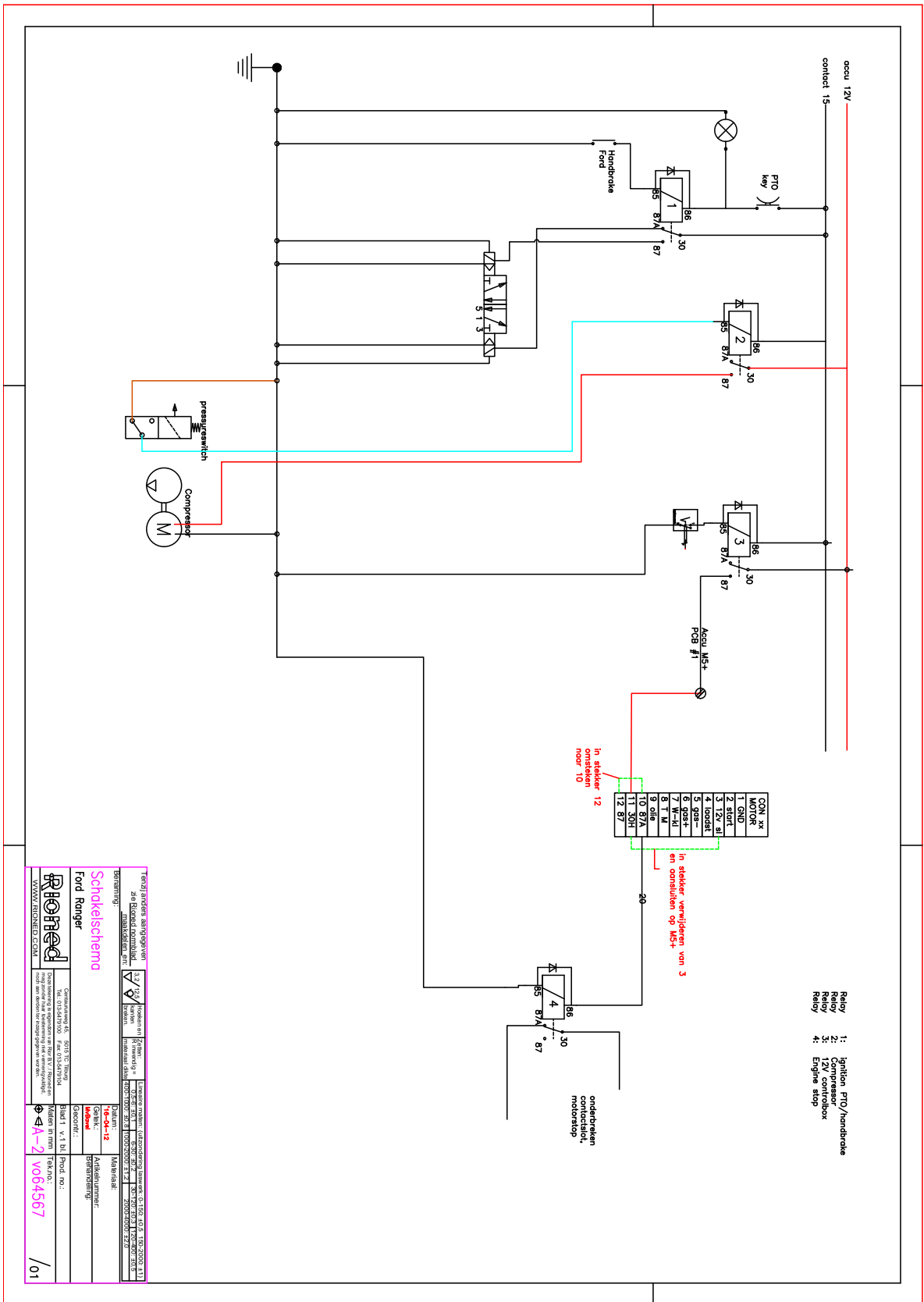

12.6 Wiring lights

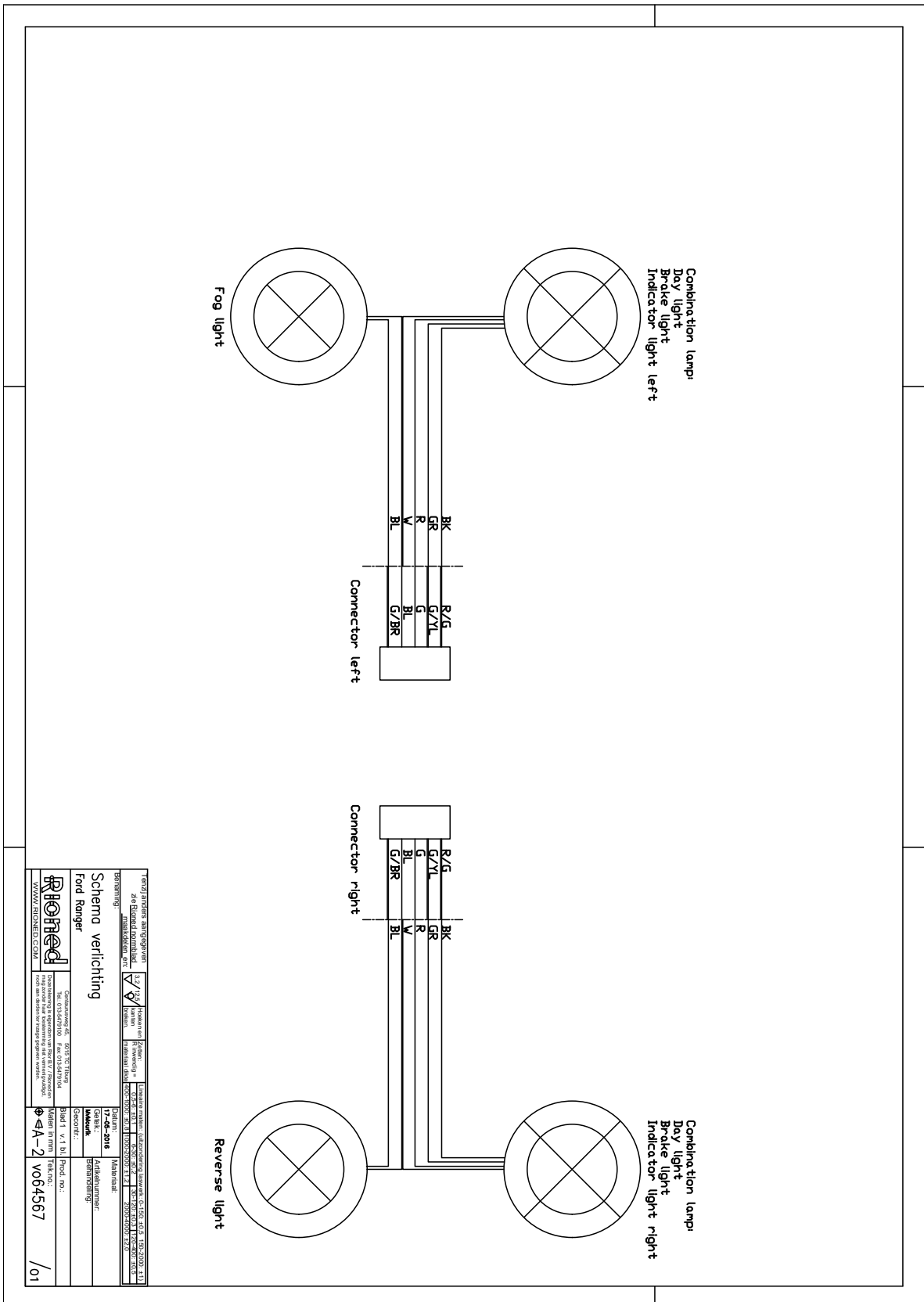

TECHNISCHE TOEGANGSVOORWAARDEN	3,2 / 100	1/1000	1/1000	1/1000	1/1000	1/1000	1/1000	1/1000
Bestelnummer:	20070007-20-31	20070007-20-31	20070007-20-31	20070007-20-31	20070007-20-31	20070007-20-31	20070007-20-31	20070007-20-31
Schema verlichting								
Ford Ranger								
Bestel 1 v.1 bl. Prod. no.: 4A-2 V064567 /01								

12.7 Hydraulic oil

Important!

You have to renew the environment friendly hydraulic oil ones a year.

Description

Hydraulic oil is an environment friendly oil based on vegetable oil. By use of natural vegetable oil, the hydraulic oil is neutral for the environment and is biologically decomposable. When spilling some oil, the ground as well the around water are less damaged by contamination.

Characteristics

It is possible to use the oil for a wide temperature range by having of good viscosity from different temperatures.

The good lubrication characters take care of protection against wastage.

If this oil should be used, one have to remind that the standing time of this oil is shorter than the standing time of a premium mineral hydraulic oil.

The quick connect couplings can get stocked in consequence of the resinification of spilled oil. It's recommended to remove the spilled oil as soon as possible.

This oil meets the requirements of the lubrication technical characteristics, like they are being stated in DIN 51 524, part two for HPL hydraulic oils.

This oil goes well together with elastomer, which is made of nitrorubber, polyacrylate, silicone and epihydrogen chloride.

Use

This oil is universal as hydraulic oil and is very suitable for use in hydraulic installations, which are being used often in environmental areas, like: close to rivers and lakes in water catchments areas in the wood construction

Precautionary measures

The mixing with motor oils has a negative influence for quality of this oil; consequences: formation of foam and obstruction of filters.

Hygiene and health

This oil is a safe product, but too much and long contact with skin is bad and one also have to take care of personal hygiene. If some more information is needed with regards to toxicology or the safety of petroleum products please do not hesitate to contact us.

12.8 Hydraulic scheme

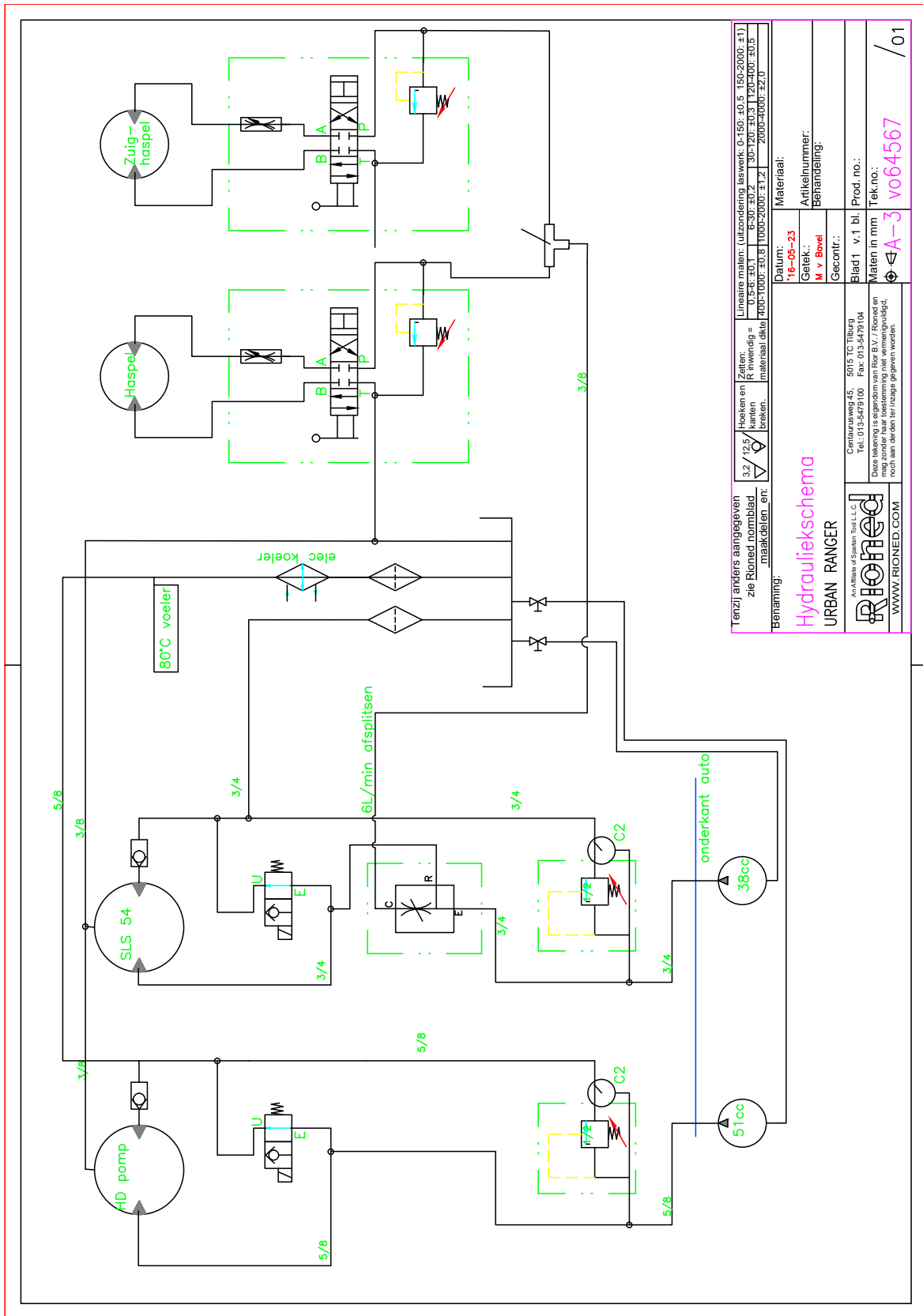

Tenzij anders aangegeven zie Riomed nomtblad maakdelen en:	3,2 / 12,5 / Heekken en kanten breken.	Zetten: R inwendig = 1000-2000 ±12	Lineaire maten: (uitzondering laswerk: 0-150: ±0,5 150-2000: ±1) 0-50: ±0,1 50-100: ±0,2 100-200: ±0,3 200-400: ±0,5
Benaming:	Hydrauliekschema		
	URBAN RANGER		
	An Affiliée of Spanan Tool L.L.C.		
	Centraalweg 45, 5015 TC Tilburg, Tel: 013-5479100 Fax: 013-5479104		
	Blad 1 v.1 bl.		
	Prod. no.:		
	Tek. no.:		
	A-3 v064567 / 01		

12.9 Dimensions

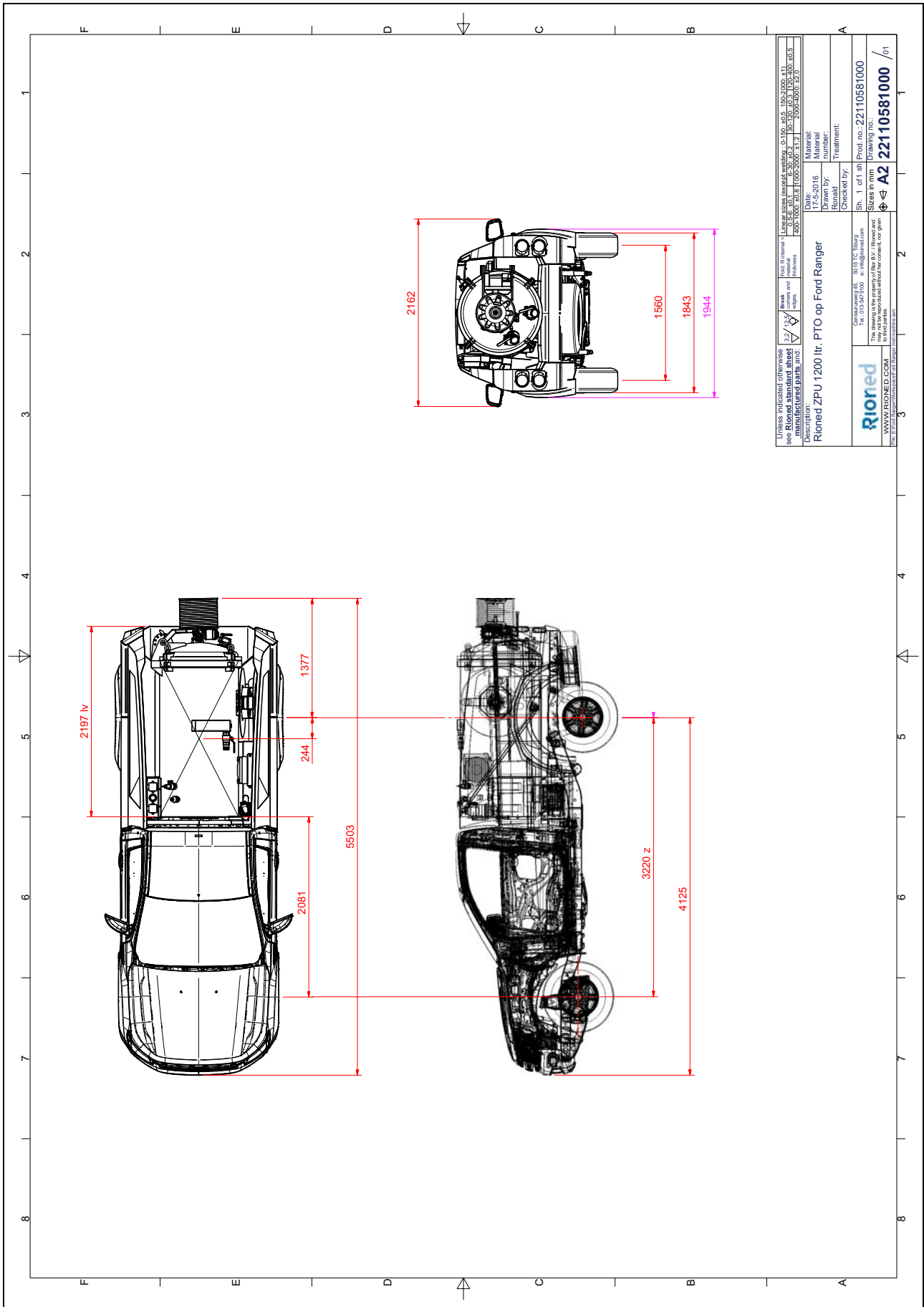

12.10 Pneumatic circuit

100	1	Compressor 327/CDC56/12	58500012112
110	1	MW terugslagklep VNR 3"	58500012805
120	1	MW luchttank 5 liter 1/2"	58500012856
130	1	drukschakelaar	58500012855
140	1	MW reduceerventiel MR 1/4"	58500012807
170	1	OMSI tussenbak PFT300	47500200203
180	2	12V spoel t.b.v. pneumatisch ventiel	58500012851
190	1	5/2 Bistab pneum. magneetventiel	58500012850
200	2	MW geluidsdemper 1/4"	58500012852
210	1	MW manometer rond 40	58500012813
220	1	Drukschakelaar PE	58500012002

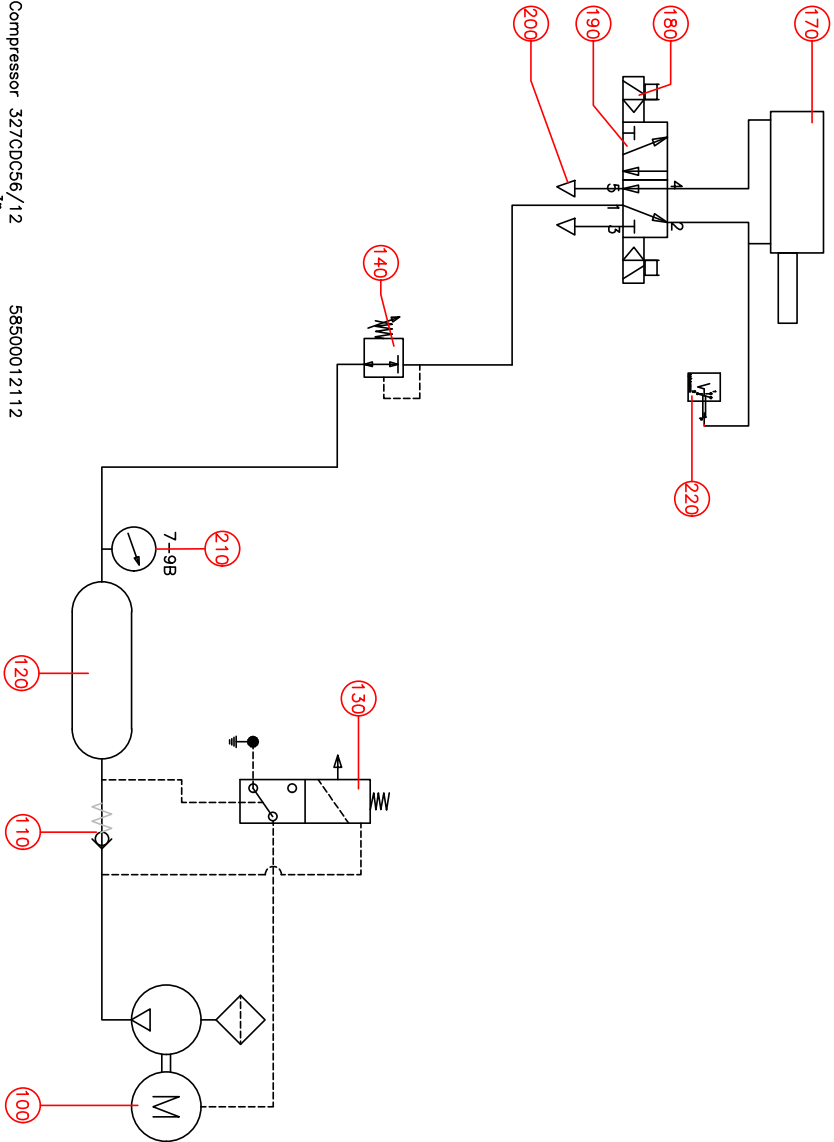

Tenzij anders aangegeven zie Rioned normblad maatkleden, en:		3/2, 1/2, 5/ kanten breken	Hoeken en Zetten: R. inwendig = materiaal dikte	Lineaire maten: (uitzondering lasveek: 0-150: ±0.5 150-2000: ±1) 015-6: ±0.1 6-30: ±0.2 30-120: ±0.3 120-400: ±0.5 400-1000: ±0.8 1000-2000: ±1.2 2000-4000: ±2.0
Benaming: Urban Ronger		Datum: 16-04-12	Materiaal:	
Rioned www.rioned.com		Gecont.:	Artikelnummer: Bestelling:	
Centaursweg 45, 5015 TC Tilburg Tel.: 013-5479100 Fax: 013-5479104 Deze tekening is eigendom van Rion BV / Rioned en mag zonder haar toestemming niet verspreid of noch aan derden ter inzage gegeven worden.		Blad 1 v.1 bl.	Prod. no.: Tek.no.:	
A-3		v064567 / 01		

13 INDEX

A

accessories 11
antifreeze 29
appropriate attachment 21
Article number 13
Attention27, ... 45

B

built by 7

C

Carriage 45
Caution28, ... 32
Ceramic plunger 49
Changing the pump oil 46
Characteristics 63
chemicals 7
Cleaning 45
Copyright 2

D

Decalcify pressure valves 48
Decalcify suction valves 48
dipstick 46
dipsticks 21

E

Emergency stop 9, ... 21
explosive environment 7
exposure 10

F

Failure 49
failure 10
flammable material .. 7
Follow number 13
forbidden 7
Foreword 3
fundamental conditions 9

G

general conditions of delivery
..... 11
general delivery conditions 7
general security signs 9
Gloves 9

H

Hygiene and health 63

I

Important 13, .. 46,
63
injuries 11
Interval 48

L

lightning 7

M

Machine number 13
Magnet coupling 50
main parts 15
maximum water temperature
..... 21
mechanical failures . 10

N

Nozzle 49
nozzle 21

O

Oil level 45
oil level 21
ordering spare parts 13
original spare parts . 11
Over-pressure valve .9

P

Precautionary measures 63

Pressure regulator 9
professional user 3
protection facilities . 11
Protection looking glasses 9
Pump system 45
Puncture nozzle holes 48

Q

qualifications 10
qualified personnel ... 9

R

Reason 49
responsible 9
RIONED 7
Rioned 2, ... 11,
47, 57

S

Sales managers 58
Security covers 9
security regulations .. 9
Security sign 9
sharp objects 27
Solution 49
special repair couplings 27
spray lance gun 22
Stop spraying 27, ... 32
Stop working 28
supply pipe 21

T

traffic 27
transmitter 50

V

vegetable oil 63
ventilation 7

W

Warning signal 51
warranty 11
wastage 63
weather conditions ... 7

Y

Year of constructions 13